

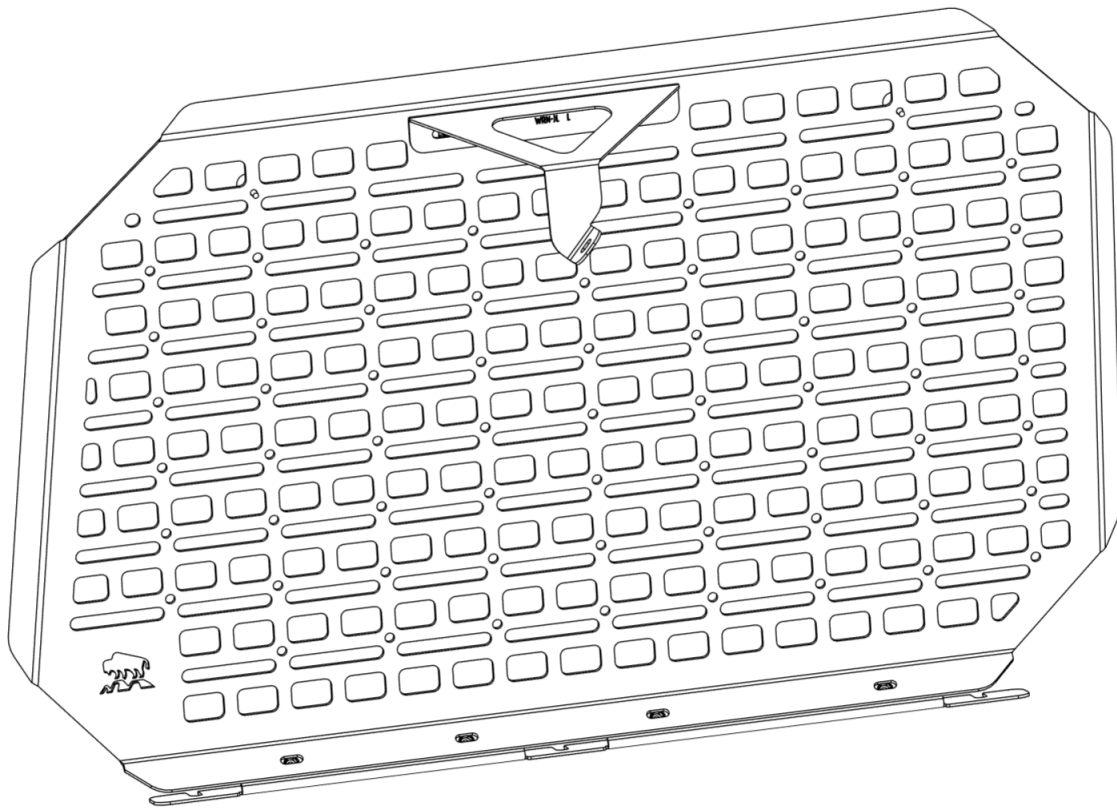

BISON GEAR

Jeep Wrangler JL Internal Molle panel Installation Guide

WINPAN-WRN-JL-L; WINPAN-WRN-JL-R





Before you start



Familiarize yourself with these instructions. **The Internal MOLLE Panel** is shipped in one parcel. Ensure that all listed parts and hardware are present in package. Locate a flat surface or floor with a minimum area of 1x1 m. Gather the required tools. We recommend **one adult person** to help.

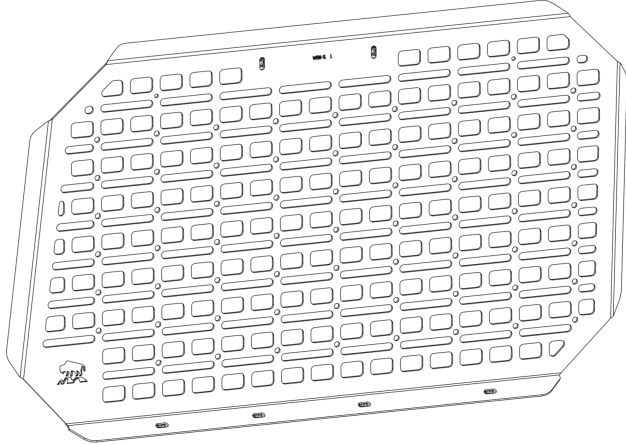
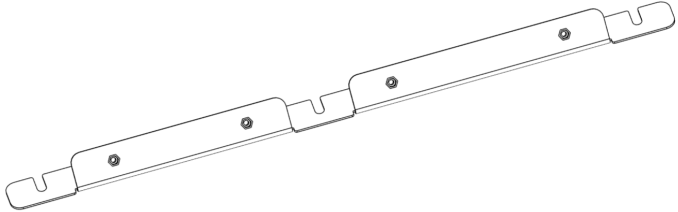
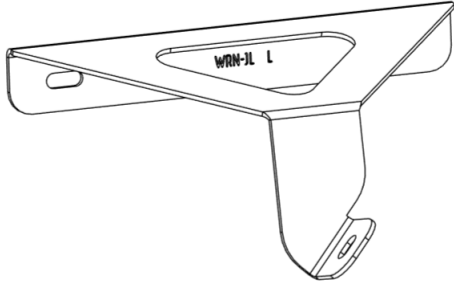

Part list – Left panel

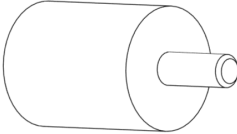
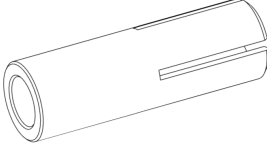

LP	PART	QTY	IMAGE
1	WINPAN-WRN-JL Left panel	1	
2	WINPAN-WRN-JL Left lower bracket	1	
3	WINPAN-WRN-JL Left upper bracket	1	
4	WINPAN-WRN-JL Upper plate nut	1	

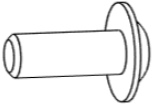



5	Rubber buffer DVA.4-15-20-M4	2	
6	Expansion sleeve M6	1	
7	Flange nut M4 DIN 6923	2	
8	Flange Bolt M6x16 ISO 7380-2	7	

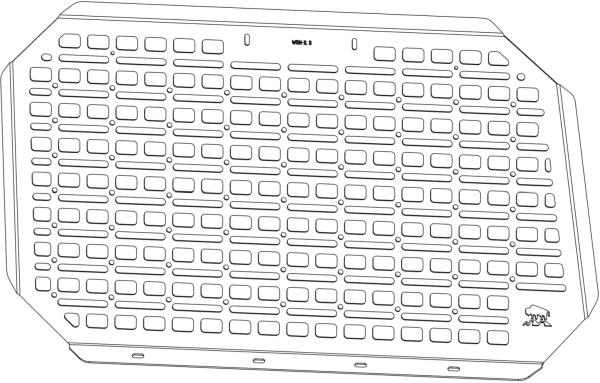
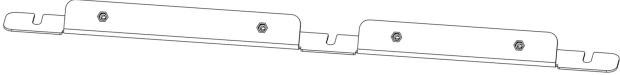
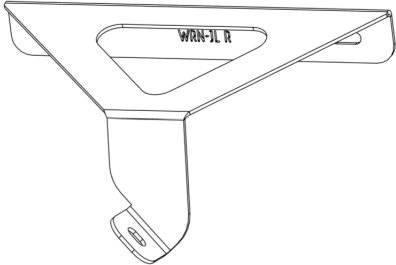

Part list – Right panel

LP	PART	QTY	IMAGE
1	WINPAN-WRN-JL Right panel	1	
2	WINPAN-WRN-JL Right lower bracket	1	
3	WINPAN-WRN-JL Right upper bracket	1	
4	WINPAN-WRN-JL Upper plate nut	1	

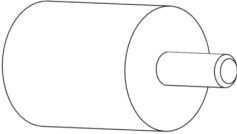
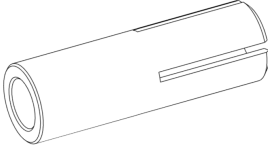

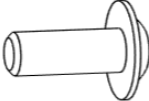
5	Rubber buffer DVA.4-15-20-M4	2	
6	Expansion sleeve M6	1	
7	Flange nut M4 DIN 6923	2	
8	Flange Bolt M6x16 ISO 7380-2	7	

List of necessary tools¹:

- 4 mm Allen Key (Hex)
- 7 mm wrench
- TX 40 Torx Key (included in Jeep's hard top removing set)

¹ NOTE: The tools **are not** included in the set.



Internal MOLLE Panel Diagram

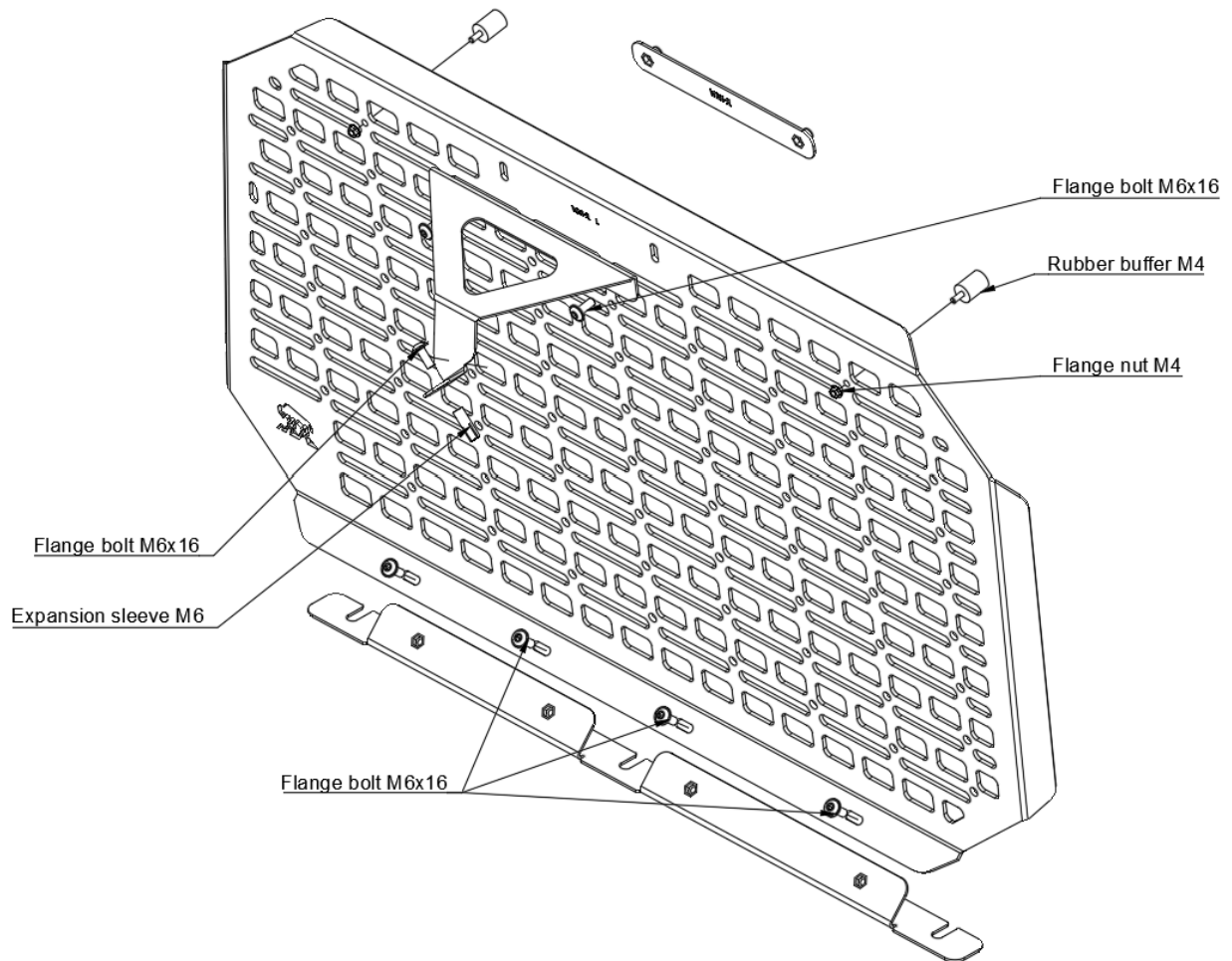



Installation:

Before you start to work, familiarize with the **Internal MOLLE Panel Diagram** on **page 6**. There is an exploded view of window panel that shows you how to install it. Follow the steps below to install the product correctly.

1. The internal window panel is mounted using the **three bolts of hardtop mount**. Unscrew the bolts until the gap underneath is more than 3mm.
2. Slide the **left lower bar under the bolts** and then tighten the bolts.

Important! (*for Bison Gear Cargo Basket users only*)

If you have a left Cargo Basket from Bison Gear, you will need to install the lower bar on the upper surface of the box. The box mounting kit includes an aluminum washer which you need to slide under the lower bar on the third bolt. It is important to have one mounting surface on the entire lower bracket.

3. Put the **panel on the window** (slide in the panel from the side of the rear seats) and pre-screw it to the lower bracket using **M6x16 bolts**.
4. Place the **expansion bolt** into the hole in the Jeep Wrangler's safety cage. (photo below).



The direction of the sleeve is very important. It should be inserted so that the metric thread is on top. The sleeve should also be inserted **approximately 10 mm under the top of the hole** (photo below).



5. Screw the **upper bracket** using **M6x16 bolt**. Regulate the position of the panel and tighten all bolts.



BISON GEAR

The right panel mount is similar for the left panel.

Make sure that everything is mounted properly, and all the bolts are tighten. If it everything is correct, your work is done.

After driving 50km, check all the bolts and re-tighten them if necessary.

Have a great time with Bison Gear product!



Email: contact@bison-gear.com

Phone: +48 505 642 981